



B-Serie

Process Automat B22

Technical Data

Titel	B22	B22	B22	B22
Type	250	250	250	250
Execution	-300	-600	-900	-1400
Nominal volume (l)	300	600	900	1 400
Pre-cutter	2 knives			
Drive pre-cutter (kW)	11	11 (13,5 / 17,5)	13,5 / 17,5	13,5 / 17,5 (34)
Emulsifiers (mm)	KS Cutting System with 1 hole plate Ø 150			
Drive emulsifier (kW)	11	11	11	11
Weight, approx.* (kg)	550	750	1 000	1 700 - 3 000

*) Depending on the machine execution.

We reserve the right to make technical changes without prior notice.

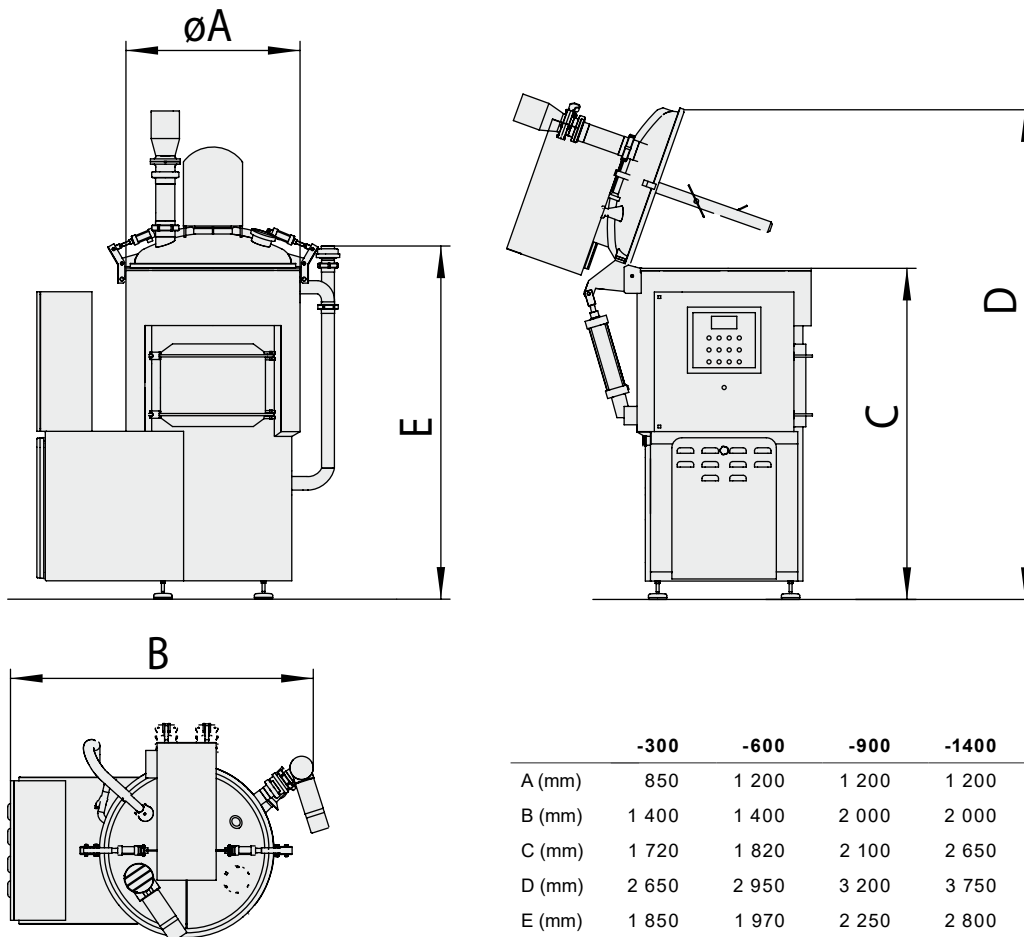

KARL SCHNELL GmbH & Co.KG
Mühlstraße 30 • Germany
D-73650 Winterbach
Phone +49 (0) 7181 / 9 62 - 0
Telefax +49 (0) 7181 / 9 62 - 100
www.karlschnell.de
ks@karlschnell.de